



US008825475B2

(12) **United States Patent**
Eksler

(10) **Patent No.:** **US 8,825,475 B2**

(45) **Date of Patent:** ***Sep. 2, 2014**

(54) **TRANSFORM-DOMAIN CODEBOOK IN A CELP CODER AND DECODER**

6,453,289 B1 * 9/2002 Ertem et al. 704/225
7,106,228 B2 9/2006 Bessette et al.
2003/0009325 A1 * 1/2003 Kirchherr et al. 704/211

(75) Inventor: **Vaclav Eksler**, Sherbrooke (CA)

(Continued)

(73) Assignee: **Voiceage Corporation**, Town of Mount Royal, Quebec (CA)

FOREIGN PATENT DOCUMENTS

(*) Notice: Subject to any disclaimer, the term of this patent is extended or adjusted under 35 U.S.C. 154(b) by 0 days.

WO 2009/033288 3/2009
WO 2011/048094 4/2011

This patent is subject to a terminal disclaimer.

OTHER PUBLICATIONS

Bessette et al., "Universal Speech/Audio Coding Using Hybrid ACELP/TCX Techniques", 2005 IEEE International Conference on Speech, Acoustics and Signal Processing, ICASSP '05, vol. 3, Mar. 23, 2005, pp. III/301-III/304.

(21) Appl. No.: **13/469,744**

(22) Filed: **May 11, 2012**

(Continued)

(65) **Prior Publication Data**

US 2012/0290295 A1 Nov. 15, 2012

Primary Examiner — Richemond Dorvil

Assistant Examiner — Thuykhanh Le

Related U.S. Application Data

(74) *Attorney, Agent, or Firm* — Fay Kaplun & Marcin, LLP

(60) Provisional application No. 61/484,968, filed on May 11, 2011.

(57) **ABSTRACT**

(51) **Int. Cl.**

G10L 19/12 (2013.01)
G10L 19/00 (2013.01)
G10L 21/00 (2013.01)
G10L 21/04 (2013.01)

Codebook Arrangement for use in coding an input sound signal includes First and Second Codebook Stages. First Codebook Stage includes one of a time-domain CELP codebook and a transform-domain codebook. Second Codebook Stage follows the first codebook stage and includes the other of the time-domain CELP codebook and the transform-domain codebook. Codebook Stage includes an adaptive codebook may be provided before First Codebook Stage. A selector may be provided to select an order of the time-domain CELP codebook and the transform-domain codebook in First and Second Codebook Stages, respectively, as a function of characteristics of the input sound signal. The selector may also be responsive to both the characteristics of the input sound signal and a bit rate of the codec using Codebook Arrangement to bypass Second Codebook Stage. Codebook Arrangement can be used in a coder of an input sound signal.

(52) **U.S. Cl.**

CPC **G10L 19/12** (2013.01)
USPC **704/219**; 704/220; 704/222; 704/223;
704/500; 704/501; 704/502; 704/503; 704/504

(58) **Field of Classification Search**

None
See application file for complete search history.

(56) **References Cited**

U.S. PATENT DOCUMENTS

6,108,626 A * 8/2000 Cellario et al. 704/230
6,134,518 A * 10/2000 Cohen et al. 704/201

32 Claims, 6 Drawing Sheets

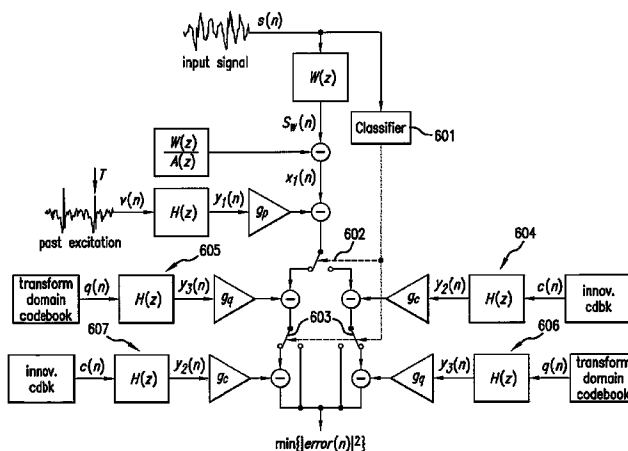

(56)

References Cited

U.S. PATENT DOCUMENTS

2003/0191635 A1* 10/2003 Minde et al. 704/220
2006/0036435 A1* 2/2006 Kovesi et al. 704/229
2006/0173677 A1* 8/2006 Sato et al. 704/223
2007/0225971 A1* 9/2007 Bessette 704/203
2009/0024386 A1* 1/2009 Su et al. 704/201
2009/0240491 A1* 9/2009 Reznik 704/219
2009/0306992 A1* 12/2009 Ragot et al. 704/500
2010/0088089 A1* 4/2010 Hardwick 704/208
2010/0241425 A1* 9/2010 Eksler et al. 704/220
2011/0010168 A1* 1/2011 Yu et al. 704/219

2011/0082693 A1* 4/2011 Krishnan et al. 704/225
2011/0224994 A1* 9/2011 Norvell et al. 704/500
2012/0089389 A1 4/2012 Bessette et al.
2012/0185256 A1* 7/2012 Virette et al. 704/500

OTHER PUBLICATIONS

3GPP TS 26.290 V61.1, 3rd Generation Partnership Project, Technical Specification Group Services and System Aspects; Speech Codec Speech Processing Functions; Adaptive Multi-Rate-Wideband (AMR-WB) Speech Codec; Transcoding Functions, Release 6, Jul. 2005, pp. 1-53.

* cited by examiner

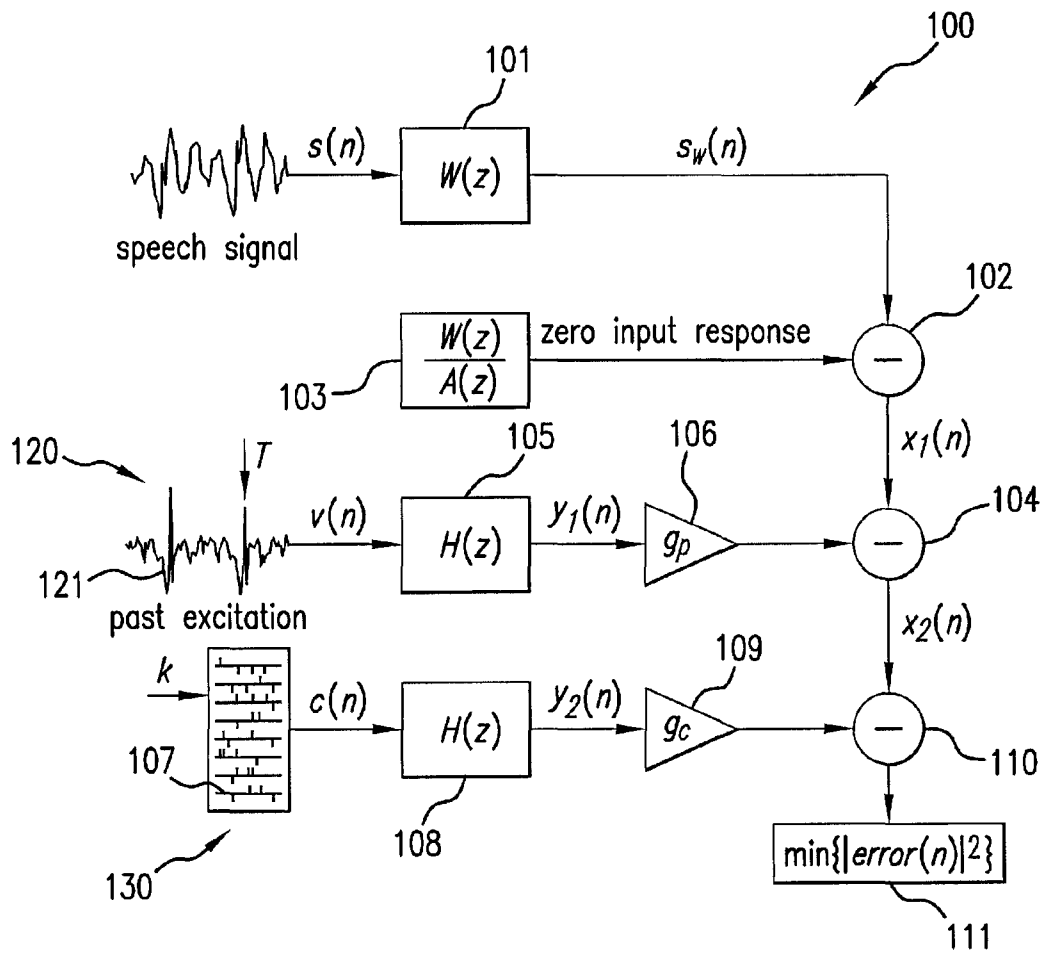

FIG. 1

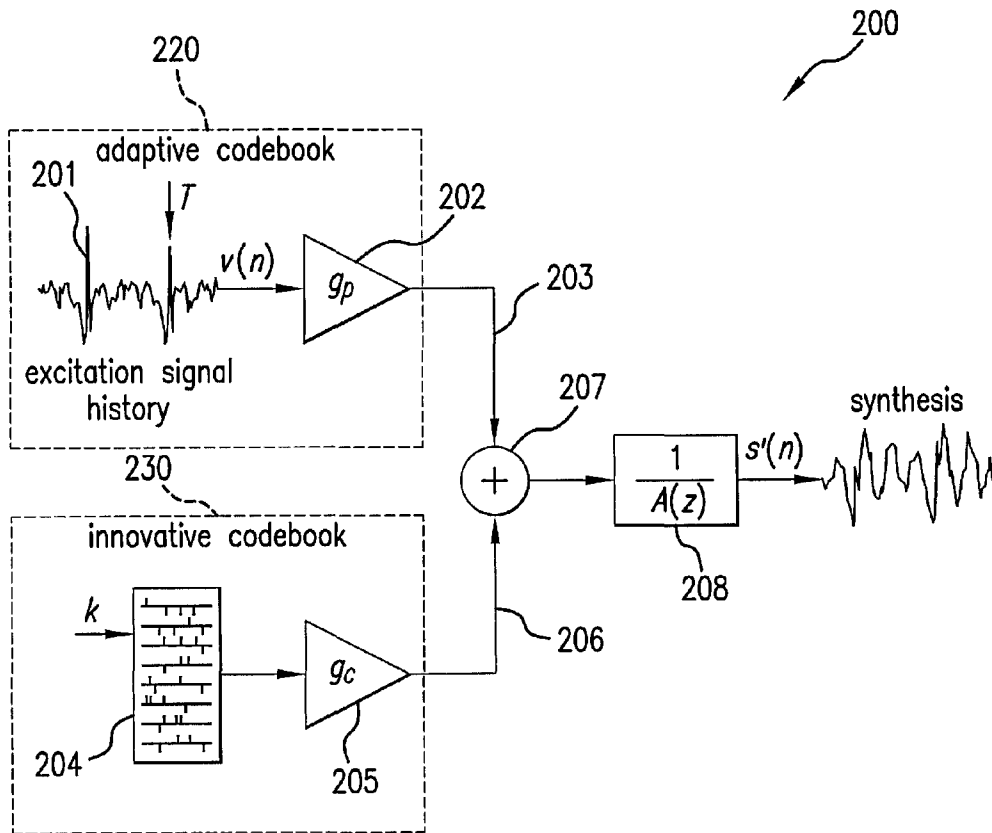

FIG. 2

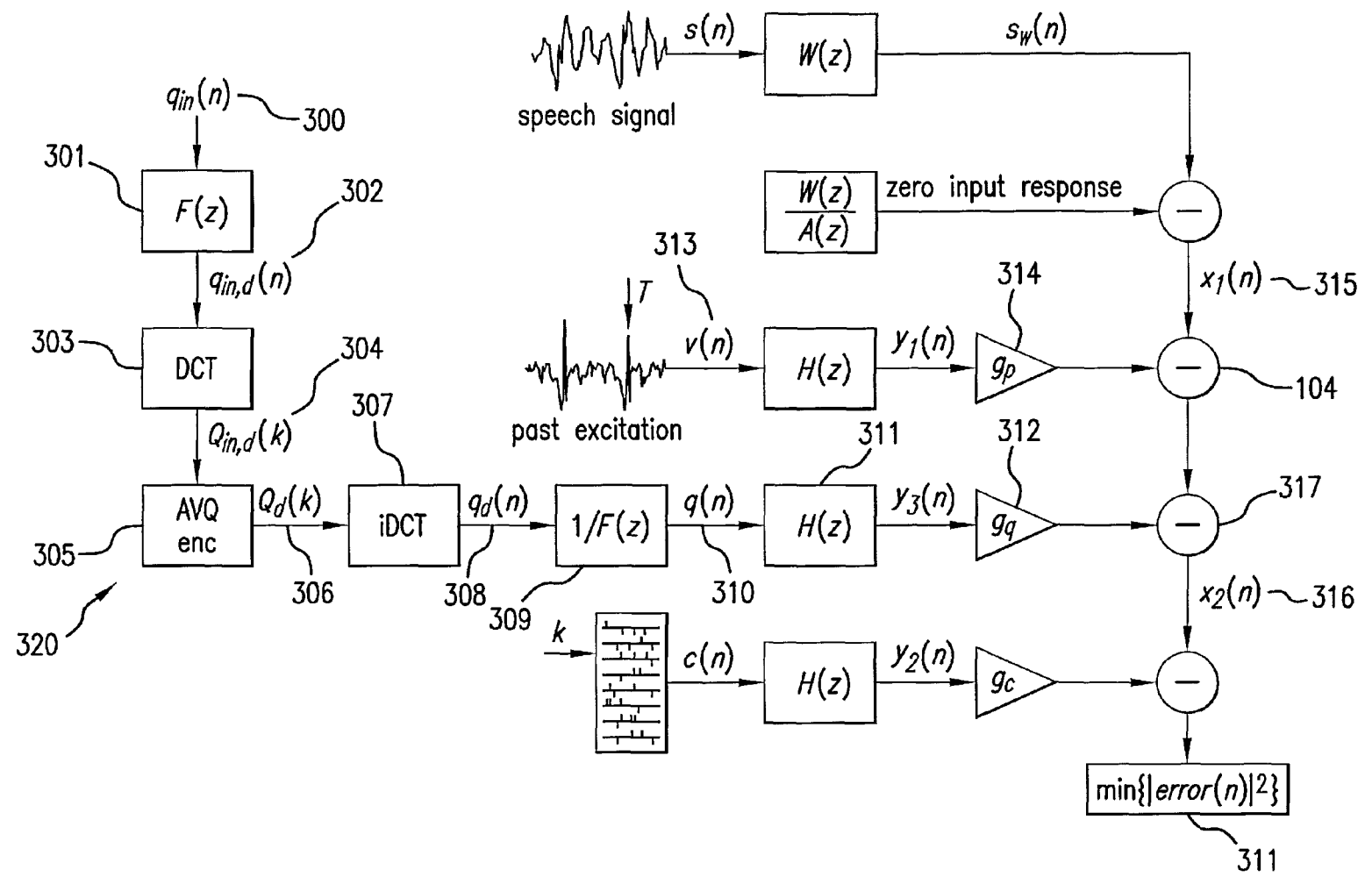

FIG. 3

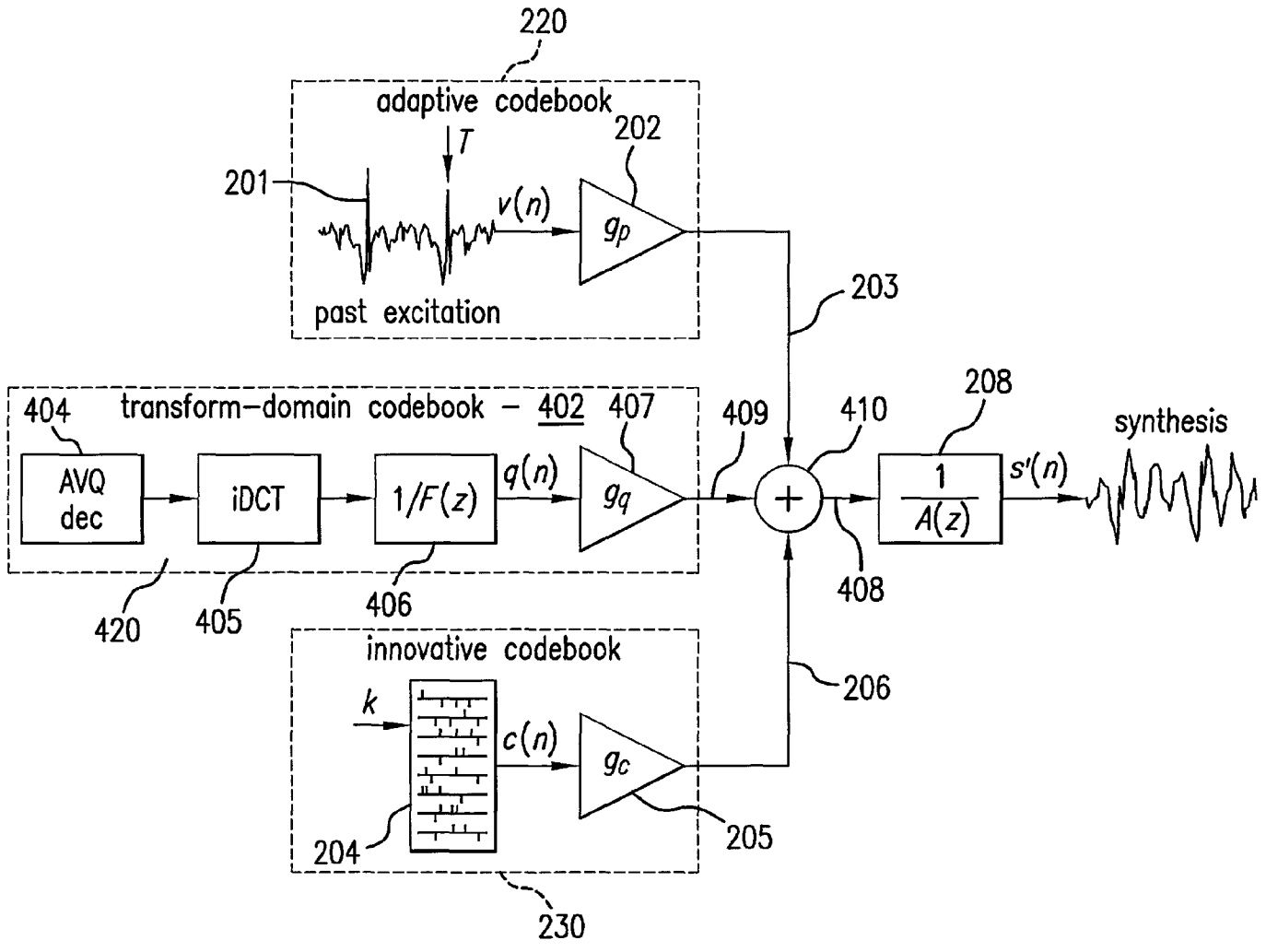

FIG. 4

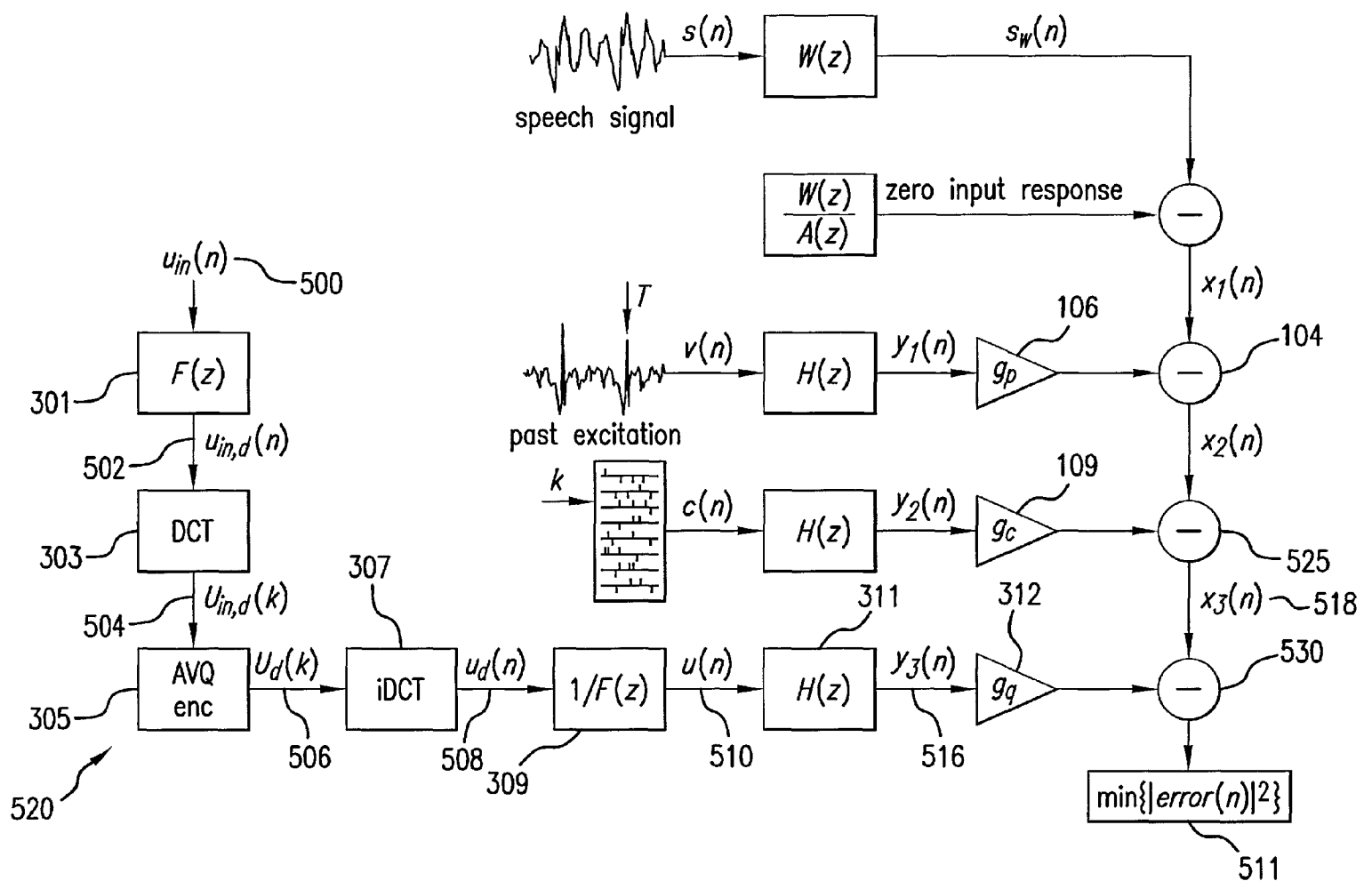

FIG. 5

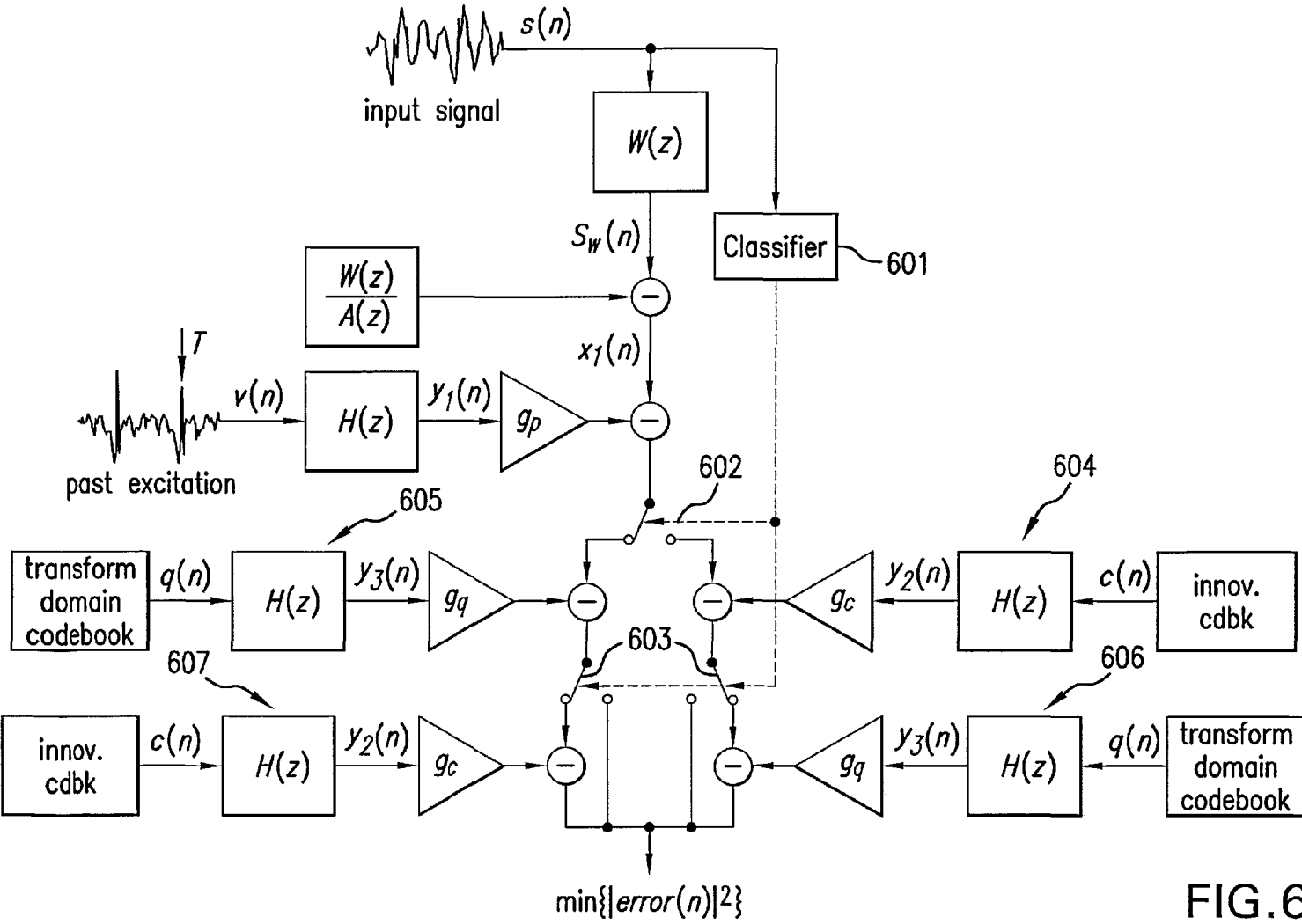

FIG. 6

1

TRANSFORM-DOMAIN CODEBOOK IN A CELP CODER AND DECODER

FIELD

The present disclosure relates to a codebook arrangement for use in coding an input sound signal, and a coder using such codebook arrangement.

BACKGROUND

The Code-Excited Linear Prediction (CELP) model is widely used to encode sound signals, for example speech, at low bit rates.

In CELP coding, the speech signal is sampled and processed in successive blocks of a predetermined number of samples usually called frames, each corresponding typically to 10-30 ms of speech. The frames are in turn divided into smaller blocks called sub-frames.

In CELP, the signal is modelled as an excitation processed through a time-varying synthesis filter $1/A(z)$. The time-varying synthesis filter may take many forms, but very often a linear recursive all-pole filter is used. The inverse of the time-varying synthesis filter, which is thus a linear all-zero non-recursive filter $A(z)$, is defined as a short-term predictor (STP) since it comprises coefficients calculated in such a manner as to minimize a prediction error between a sample $s(n)$ of the input sound signal and a weighted sum of the previous samples $s(n-1)$, $s(n-2)$, \dots , $s(n-m)$, where m is the order of the filter and n is a discrete time domain index, $n=0, \dots, L-1$, L being the length of an analysis window. Another denomination frequently used for the STP is Linear Predictor (LP).

If the prediction error from the LP filter is applied as the input of the time-varying synthesis filter with proper initial state, the output of the synthesis filter is the original sound signal, for example speech. At low bit rates, it is not possible to transmit the exact error residual (minimized prediction error from the LP filter). Accordingly, the error residual is encoded to form an approximation referred to as the excitation. In CELP coders, the excitation is encoded as the sum of two contributions, the first contribution taken from a so-called adaptive codebook and the second contribution from a so-called innovative or fixed codebook. The adaptive codebook is essentially a block of samples $v(n)$ from the past excitation signal (delayed by a delay parameter t) and scaled with a proper gain g_a . The innovative or fixed codebook is populated with vectors having the task of encoding a prediction residual from the STP and adaptive codebook. The innovative or fixed codebook vector $c(n)$ is also scaled with a proper gain g_c . The innovative or fixed codebook can be designed using many structures and constraints. However, in modern speech coding systems, the Algebraic Code-Excited Linear Prediction (ACELP) model is used. An example of an ACELP implementation is described in [3GPP TS 26.190 "Adaptive Multi-Rate-Wideband (AMR-WB) speech codec; Transcoding functions"] and, accordingly, ACELP will only be briefly described in the present disclosure. Also, the full content of this reference is herein incorporated by reference.

Although very efficient to encode speech at low bit rates, ACELP codebooks cannot gain in quality as quickly as other approaches (for example transform coding and vector quantization) when increasing the ACELP codebook size. When measured in dB/bit/sample, the gain in quality at higher bit rates (for example bit rates higher than 16 kbits/s) obtained by using more non-zero pulses per track in an ACELP codebook is not as large as the gain in quality (in dB/bit/sample) at

2

higher bit rates obtained with transform coding and vector quantization. This can be seen when considering that ACELP essentially encodes the sound signal as a sum of delayed and scaled impulse responses of the time-varying synthesis filter.

At lower bit rates (for example bit rates lower than 12 kbits/s), the ACELP model captures quickly the essential components of the excitation. But at higher bit rates, higher granularity and, in particular, a better control over how the additional bits are spent across the different frequency components of the signal are useful.

BRIEF DESCRIPTION OF THE DRAWINGS

In the appended drawings:

FIG. 1 is a schematic block diagram of an example of CELP coder using, in this non-limitative example, ACELP;

FIG. 2 is a schematic block diagram of an example of CELP decoder using, in this non-limitative example, ACELP;

FIG. 3 is a schematic block diagram of a CELP coder using a first structure of modified CELP model, and including a first codebook arrangement;

FIG. 4 is a schematic block diagram of a CELP decoder in accordance with the first structure of modified CELP model;

FIG. 5 is a schematic block diagram of a CELP coder using a second structure of modified CELP model, including a second codebook arrangement; and

FIG. 6 is a schematic block diagram of an example of general, modified CELP coder with a classifier for choosing between different codebook structures.

DETAILED DESCRIPTION

In accordance with a non-restrictive, illustrative embodiment, there is provided a codebook arrangement for use in coding an input sound signal, comprising:

a first codebook stage including one of a time-domain CELP codebook and a transform-domain codebook; and

a second codebook stage following the first codebook stage and including the other of the time-domain CELP codebook and the transform-domain codebook.

According to another non-restrictive, illustrative embodiment, there is provided a coder of an input sound signal, comprising:

a first, adaptive codebook stage structured to search an adaptive codebook to find an adaptive codebook index and an adaptive codebook gain;

a second codebook stage including one of a time-domain CELP codebook and a transform-domain codebook; and

a third codebook stage following the second codebook stage and including the other of the time-domain CELP codebook and the transform-domain codebook;

wherein the second and third codebook stages are structured to search the respective time-domain CELP codebook and transform-domain codebook to find an innovative codebook index, an innovative codebook gain, transform-domain coefficients, and a transform-domain codebook gain.

Optionally, there may be provided a selector of an order of the time-domain CELP codebook and the transform-domain codebook in the second and third codebook stages, respectively, as a function of at least one of (a) characteristics of the input sound signal and (b) a bit rate of a codec using the codebook arrangement.

The foregoing and other features of the codebook arrangement and coder will become more apparent upon reading of the following non restrictive description of embodiments thereof, given by way of illustrative examples only with reference to the accompanying drawings.

FIG. 1 shows the main components of an ACELP coder **100**.

In FIG. 1, $y_1(n)$ is the filtered adaptive codebook excitation signal (i.e. the zero-state response of the weighted synthesis filter to the adaptive codebook vector $v(n)$), and $y_2(n)$ is similarly the filtered innovative codebook excitation signal. The signals $x_1(n)$ and $x_2(n)$ are target signals for the adaptive and the innovative codebook searches, respectively. The weighted synthesis filter, denoted as $H(z)$, is the cascade of the LP synthesis filter $1/A(z)$ and a perceptual weighting filter $W(z)$, i.e. $H(z)=[1/A(z)] \cdot W(z)$.

The LP filter $A(z)$ may present, for example, in the z-transform, the transfer function

$$A(z) = \sum_{i=0}^M a_i z^{-i},$$

where a_i represent the linear prediction coefficients (LP coefficients) with $a_0=1$, and M is the number of linear prediction coefficients (order of LP analysis). The LP coefficients a_i are determined in an LP analyzer (not shown) of the ACELP coder **100**. The LP analyzer is described for example in the aforementioned article [3GPP TS 26.190 “Adaptive Multi-Rate-Wideband (AMR-WB) speech codec; Transcoding functions”] and, therefore, will not be further described in the present disclosure.

An example of perceptual weighting filter can be $W(z)=A(z/\gamma_1)/A(z/\gamma_2)$ where γ_1 and γ_2 are constants having a value between 0 and 1 and determining the frequency response of the perceptual weighting filter $W(z)$.

Adaptive Codebook Search

In the ACELP coder **100** of FIG. 1, an adaptive codebook search is performed in the adaptive codebook stage **120** during each sub-frame by minimizing the mean-squared weighted error between the original and synthesized speech. This is achieved by maximizing the term

$$\mathcal{J}_t = \frac{\left(\sum_{n=0}^{N-1} x_1(n)y_1(n) \right)^2}{\sum_{n=0}^{N-1} y_1(n)y_1(n)}, \quad (1)$$

where $x_1(n)$ is the above mentioned target signal, $y_1(n)$ is the above mentioned filtered adaptive codebook excitation signal, and N is the length of a sub-frame.

Target signal $x_1(n)$ is obtained by first processing the input sound signal $s(n)$, for example speech, through the perceptual weighting filter $W(z)$ **101** to obtain a perceptually weighted input sound signal $s_w(n)$. A subtractor **102** then subtracts the zero-input response of the weighted synthesis filter $H(z)$ **103** from the perceptually weighted input sound signal $s_w(n)$ to obtain the target signal $x_1(n)$ for the adaptive codebook search. The perceptual weighting filter $W(z)$ **101**, the weighted synthesis filter $H(z)=W(z)/A(z)$ **103**, and the subtractor **102** may be collectively defined as a calculator of the target signal $x_1(n)$ for the adaptive codebook search.

An adaptive codebook index T (pitch delay) is found during the adaptive codebook search. Then the adaptive codebook gain g_p (pitch gain), for the adaptive codebook index T found during the adaptive codebook search, is given by

$$g_p = \frac{\sum_{n=0}^{N-1} x_1(n)y_1^{(T)}(n)}{\sum_{n=0}^{N-1} y_1(n)y_1^{(T)}(n)}. \quad (2)$$

For simplicity, the codebook index T is dropped from the notation of the filtered adaptive codebook excitation signal. Thus signal $y_1(n)$ is equivalent to the signal $y_1^{(T)}(n)$.

The adaptive codebook index T and adaptive codebook gain g_p are quantized and transmitted to the decoder as adaptive codebook parameters. The adaptive codebook search is described in the aforementioned article [3GPP TS 26.190 “Adaptive Multi-Rate-Wideband (AMR-WB) speech codec; Transcoding functions”] and, therefore, will not be further described in the present disclosure.

Innovative Codebook Search

An innovative codebook search is performed in the innovative codebook stage **130** by minimizing, in the calculator **111**, the mean square weighted error after removing the adaptive codebook contribution, i.e.

$$E = \min_k \left\{ \sum_{n=0}^{N-1} [x_2(n) - g_c \cdot y_2^{(k)}(n)]^2 \right\}, \quad (3)$$

where the target signal $x_2(n)$ for the innovative codebook search is computed by subtracting, through a subtractor **104**, the adaptive codebook excitation contribution $g_p \cdot y_1(n)$ from the adaptive codebook target signal $x_1(n)$.

$$x_2(n) = x_1(n) - g_p \cdot y_1(n). \quad (4)$$

The adaptive codebook excitation contribution is calculated in the adaptive codebook stage **120** by processing the adaptive codebook vector $v(n)$ at the adaptive codebook index T from an adaptive codebook **121** (time-domain CELP codebook) through the weighted synthesis filter $H(z)$ **105** to obtain the filtered adaptive codebook excitation signal $y_1(n)$ (i.e. the zero-state response of the weighted synthesis filter **105** to the adaptive codebook vector $v(n)$), and by amplifying the filtered adaptive codebook excitation signal $y_1(n)$ by the adaptive codebook gain g_p using amplifier **106**.

The innovative codebook excitation contribution $g_c \cdot y_2^{(k)}(n)$ of Equation (3) is calculated in the innovative codebook stage **130** by applying an innovative codebook index k to an innovative codebook **107** to produce an innovative codebook vector $c(n)$. The innovative codebook vector $c(n)$ is then processed through the weighted synthesis filter $H(z)$ **108** to produce the filtered innovative codebook excitation signal $y_2^{(k)}(n)$. The filtered innovative codebook excitation signal $y_2^{(k)}(n)$ is then amplified, by means of an amplifier **109**, with innovation codebook gain g_c to produce the innovative codebook excitation contribution $g_c \cdot y_2^{(k)}(n)$ of Equation (3). Finally, a subtractor **110** calculate the term $x_2(n) - g_c \cdot y_2^{(k)}(n)$. The calculator **111** then squares the latter term and sums this term with other corresponding terms $x_2(n) - g_c \cdot y_2^{(k)}(n)$ at different values of n in the range from 0 to $N-1$. As indicated in Equation (3), the calculator **111** repeats these operations for different innovative codebook indexes k to find a minimum value of the mean square weighted error E at a given innovative codebook index k , and therefore complete calculation of Equation (3). The innovative codebook index k corresponding to the minimum value of the mean square weighted error E is chosen.

5

In ACELP codebooks, the innovative codebook vector $c(n)$ contains M pulses with signs s_j and positions m_j , and is thus given by

$$c(n) = \sum_{j=0}^{M-1} s_j \delta(n - m_j), \quad (5)$$

where $s_j = \pm 1$, and $\delta(n) = 1$ for $n = 0$, and $\delta(n) = 0$ for $n \neq 0$.

Finally, minimizing E from Equation (3) results in the optimum innovative codebook gain

$$g_c = \frac{\sum_{n=0}^{N-1} x_2(n) y_2(n)}{\sum_{n=0}^{N-1} (y_2(n))^2}. \quad (6)$$

The innovative codebook index k corresponding to the minimum value of the mean square weighted error E and the corresponding innovative codebook gain g_c are quantized and transmitted to the decoder as innovative codebook parameters. The innovative codebook search is described in the aforementioned article [3GPP TS 26.190 "Adaptive Multi-Rate-Wideband (AMR-WB) speech codec; Transcoding functions"] and, therefore, will not be further described in the present specification.

FIG. 2 is a schematic block diagram showing the main components and the principle of operation of an ACELP decoder **200**.

Referring to FIG. 2, the ACELP decoder **200** receives decoded adaptive codebook parameters including the adaptive codebook index T (pitch delay) and the adaptive codebook gain g_p (pitch gain). In an adaptive codebook stage **220**, the adaptive codebook index T is applied to an adaptive codebook **201** to produce an adaptive codebook vector $v(n)$ amplified with the adaptive codebook gain g_p in an amplifier **202** to produce an adaptive codebook excitation contribution **203**.

Still referring to FIG. 2, the ACELP decoder **200** also receives decoded innovative codebook parameters including the innovative codebook index k and the innovative codebook gain g_c . In an innovative codebook stage **230**, the decoded innovative codebook index k is applied to an innovative codebook **204** to output a corresponding innovative codebook vector. The vector from the innovative codebook **204** is then amplified with the innovative codebook gain g_c in amplifier **205** to produce an innovative codebook excitation contribution **206**.

The total excitation is then formed through summation in an adder **207** of the adaptive codebook excitation contribution **203** and the innovative codebook excitation contribution **206**. The total excitation is then processed through a LP synthesis filter $1/A(z)$ **208** to produce a synthesis $s'(n)$ of the original sound signal $s(n)$, for example speech.

The present disclosure teaches to modify the CELP model such that another additional codebook stage is used to form the excitation. Such another codebook is further referred to as a transform-domain codebook stage as it encodes transform-domain coefficients. The choice of a number of codebooks and their order in the CELP model are described in the following description. A general structure of a modified CELP model is further shown in FIG. 6.

6

First Structure of Modified CELP Model

FIG. 4 is a schematic block diagram showing the first structure of modified CELP model applied to a decoder using, in this non-limitative example, an ACELP decoder. The first structure of modified CELP model comprises a first codebook arrangement including an adaptive codebook stage **220**, a transform-domain codebook stage **420**, and an innovative codebook stage **230**. As illustrated in FIG. 4, the total excitation $e(n)$ **408** comprises the following contributions:

In the adaptive codebook stage **220**, an adaptive codebook vector $v(n)$ is produced by the adaptive codebook **201** in response to an adaptive codebook index T and scaled by the amplifier **202** using adaptive codebook gain g_p to produce an adaptive codebook excitation contribution **203**;

In the transform-domain codebook stage **420**, a transform-domain vector $q(n)$ is produced and scaled by an amplifier **407** using a transform-domain codebook gain g_q to produce a transform-domain codebook excitation contribution **409**; and

In the innovative codebook stage **230**, an innovative codebook vector $c(n)$ is produced by the innovative codebook **204** in response to an innovative codebook index k and scaled by the amplifier **205** using innovation codebook gain g_c to produce an innovative codebook excitation contribution **409**. This is illustrated by the following relation:

$$e(n) = g_p \cdot v(n) + g_q \cdot q(n) + g_c \cdot c(n), \quad n = 0, \dots, N-1, \quad (7)$$

This first structure of modified CELP model combines a transform-domain codebook **402** in one stage **420** followed by a time-domain ACELP codebook or innovation codebook **204** in a following stage **230**. The transform-domain codebook **402** may use, for example, a Discrete Cosine Transform (DCT) as the frequency representation of the sound signal and an Algebraic Vector Quantizer (AVQ) decoder to de-quantize the transform-domain coefficients of the DCT. It should be noted that the use of DCT and AVQ are examples only; other transforms can be implemented and other methods to quantize the transform-domain coefficients can also be used.

Computation of the Target Signal for the Transform-Domain Codebook

At the coder (FIG. 3), the transform-domain codebook of the transform-domain codebook stage **320** of the first codebook arrangement operates as follows. In a given sub-frame (aligned with the sub-frame of the innovative codebook) the target signal for the transform-domain codebook $q_{in}(n)$ **300**, i.e. the excitation residual $r(n)$ after removing the scaled adaptive codebook vector $g_p \cdot v(n)$, is computed as

$$q_{in}(n) = r(n) - g_p \cdot v(n), \quad n = 0, \dots, N-1, \quad (8)$$

where $r(n)$ is the so-called target vector in residual domain obtained by filtering the target signal $x_1(n)$ **315** through the inverse of the weighted synthesis filter $H(z)$ with zero states. The term $v(n)$ **313** represents the adaptive codebook vector and g_p **314** the adaptive codebook gain.

Pre-Emphasis Filtering

In the transform-domain codebook, the target signal for the transform-domain codebook $q_{in}(n)$ **300** is pre-emphasized with a filter $F(z)$ **301**. An example of a pre-emphasis filter is $F(z) = 1/(1 - \alpha \cdot z^{-1})$ with a difference equation given by

$$q_{in,d}(n) = q_{in}(n) + \alpha \cdot q_{in,d}(n-1), \quad (9)$$

where $q_{in}(n)$ **300** is the target signal inputted to the pre-emphasis filter $F(z)$ **301**, $q_{in,d}(n)$ **302** is the pre-emphasized target signal for the transform-domain codebook and coefficient α controls the level of pre-emphasis. In this non-limi-

tative example, if the value of α is set between 0 and 1, the pre-emphasis filter applies a spectral tilt to the target signal for the transform-domain codebook to enhance the lower frequencies.

Transform Calculation

The transform-domain codebook also comprises a transform calculator 303 for applying, for example, a DCT to the pre-emphasized target signal $q_{in,d}(n)$ 302 using, for example, a rectangular non-overlapping window to produce blocks of transform-domain DCT coefficients $Q_{in,d}(k)$ 304. The DCT-II can be used, the DCT-II being defined as

$$Q_{in,d}(k) = \sum_{n=0}^{N-1} q_{in,d}(n) \cos \left[\frac{\pi}{N} \left(n + \frac{1}{2} \right) k \right], \quad (10)$$

where $k=0, \dots, N-1$, N being the sub-frame length.

Quantization

Depending on the bit-rate, the transform-domain codebook quantizes all blocks or only some blocks of transform-domain DCT coefficients $Q_{in,d}(k)$ 304 usually corresponding to lower frequencies using, for example, an AVQ encoder 305 to produce quantized transform-domain DCT coefficients $Q_d(k)$ 306. The other, non quantized transform-domain DCT coefficients $Q_{in,d}(k)$ 304 are set to 0 (not quantized). An example of AVQ implementation can be found in U.S. Pat. No. 7,106,228 of which the content is herein incorporated by reference. The indices of the quantized and coded transform-domain coefficients 306 from the AVQ encoder 305 are transmitted as transform-domain codebook parameters to the decoder.

In every sub-frame, a bit-budget allocated to the AVQ is composed as a sum of a fixed bit-budget and a floating number of bits. The AVQ encoder 305 comprises a plurality of AVQ sub-quantizers for AVQ quantizing the transform-domain DCT coefficients $Q_{in,d}(k)$ 304. Depending on the used AVQ sub-quantizers of the encoder 305, the AVQ usually does not consume all of the allocated bits, leaving a variable number of bits available in each sub-frame. These bits are floating bits employed in the following sub-frame. The floating number of bits is equal to 0 in the first sub-frame and the floating bits resulting from the AVQ in the last sub-frame in a given frame remain unused. The previous description of the present paragraph stands for fixed bit rate coding with a fixed number of bits per frame. In a variable bit rate coding configuration, different number of bits can be used in each sub-frame in accordance with a certain distortion measure or in relation to the gain of the AVQ encoder 305. The number of bits can be controlled to attain a certain average bit rate.

Inverse Transform Calculation

To obtain the transform-domain codebook excitation contribution in the time domain, the transform-domain codebook stage 320 first inverse transforms the quantized transform-domain DCT coefficients $Q_d(k)$ 306 in an inverse transform calculator 307 using an inverse DCT (iDCT) to produce an inverse transformed, emphasized quantized excitation (inverse-transformed sound signal) $q_d(n)$ 308. The inverse DCT-II (corresponding to DCT-III up to a scale factor $2/N$) is used, and is defined as

$$q_d(n) = \frac{2}{N} \left\{ \frac{1}{2} Q_d(0) + \sum_{k=1}^{N-1} Q_d(k) \cos \left[\frac{\pi}{N} k \left(n + \frac{1}{2} \right) \right] \right\}, \quad (11)$$

where $n=0, \dots, N-1$, N being the sub-frame length.

De-Emphasis Filtering

Then a de-emphasis filter $1/F(z)$ 309 is applied to the inverse transformed, emphasized quantized excitation $q_d(n)$ 308 to obtain the time-domain excitation from the transform-domain codebook stage $q(n)$ 310. The de-emphasis filter 309 has the inverse transfer function ($1/F(z)$) of the pre-emphasis filter $F(z)$ 301. In the non-limitative example for pre-emphasis filter $F(z)$ given above in Equation (9), the difference equation of the de-emphasis filter $1/F(z)$ would be given by

$$q(n) = q_d(n) - \alpha q_d(n-1), \quad (12)$$

where, in the case of the de-emphasis filter 309, $q_d(n)$ 308 is the inverse transformed, emphasized quantized excitation $q_d(n)$ 308 and $q(n)$ 310 is the time-domain excitation signal from the transform-domain codebook stage $q(n)$.

Transform-Domain Codebook Gain Calculation and Quantization

Once the time-domain excitation signal from the transform-domain codebook stage $q(n)$ 310 is computed, a calculator (not shown) computes the transform-domain codebook gain as follows:

$$g_q = \frac{\sum_{k=0}^{N-1} Q_{in,d}(k) Q_d(k)}{\sum_{k=0}^{N-1} Q_d(k) Q_d(k)}, \quad (13)$$

where $Q_{in,d}(k)$ are the AVQ input transform-domain DCT coefficients 304, $Q_d(k)$ are the AVQ output (quantized) transform-domain DCT coefficients 304, k is the transform-domain coefficient index, $k=0, \dots, N-1$, N being the number of transform-domain DCT coefficients.

Still in the transform-domain codebook stage 320, the transform-domain codebook gain from Equation (13) is quantized as follows. First, the gain is normalized by the predicted innovation energy E_{pred} as follows:

$$g_{q,norm} = \frac{g_q}{E_{pred}}. \quad (14)$$

The predicted innovation energy E_{pred} is obtained as an average residual signal energy over all sub-frames within the given frame, with subtracting an estimate of the adaptive codebook contribution. That is

$$E_{pred} = \frac{1}{P} \sum_{i=0}^{P-1} \left[10 \log \left(\frac{1}{N} \sum_{n=0}^{N-1} r^2(n) \right) \right] - 0.5(C_{norm}(0) + C_{norm}(1)),$$

where P is the number of sub-frames, and $C_{norm}(0)$ and $C_{norm}(1)$ are the normalized correlations of the first and the second half-frames of the open-loop pitch analysis, respectively, and $r(n)$ is the target vector in residual domain.

Then the normalized gain $g_{q,norm}$ is quantized by a scalar quantizer in a logarithmic domain and finally de-normalized resulting in a quantized transform-domain codebook gain. In an illustrative example, a 6-bit scalar quantizer is used whereby the quantization levels are uniformly distributed in the log domain. The index of the quantized transform-domain codebook gain is transmitted as a transform-domain codebook parameter to the decoder.

Refinement of the Adaptive Codebook Gain

When the first structure of modified CELP model is used, the time-domain excitation signal from the transform-domain codebook stage **310** can be used to refine the original target signal for the adaptive codebook search $x_1(n)$ **315** as

$$x_{1,updt}(n) = x_1(n) - g_q \cdot y_3(n), \quad (15)$$

and the adaptive codebook stage refines the adaptive codebook gain using Equation (2) with $x_{1,updt}(n)$ used instead of $x_1(n)$. The signal $y_3(n)$ is the filtered transform-domain codebook excitation signal obtained by filtering the time-domain excitation signal from the transform-domain codebook stage $q(n)$ **310** through the weighted synthesis filter $H(z)$ **311** (i.e. the zero-state response of the weighted synthesis filter $H(z)$ **311** to the transform-domain codebook excitation contribution $q(n)$).

Computation of the Target Vector for Innovative Codebook Search

When the transform-domain codebook stage **320** is used, computation of the target signal for innovative codebook search $x_2(n)$ **316** is performed using Equation (4) with $x_1(n) = x_{1,updt}(n)$ and with $g_p = g_{p,updt}$, i.e.,

$$\begin{aligned} x_2(n) &= x_{1,updt}(n) - g_{p,updt} \cdot y_1(n) \\ &= x_1(n) - g_q \cdot y_3(n) - g_{p,updt} \cdot y_1(n) \end{aligned} \quad (16)$$

Referring to FIG. 3, amplifier **312** performs the operation $g_q \cdot y_3(n)$ to calculate the transform-domain codebook excitation contribution, and subtractors **104** and **317** perform the operation $x_1(n) - g_{p,updt} \cdot y_1(n) - g_q \cdot y_3(n)$.

Similarly, the target signal in residual domain $r(n)$ is updated for the innovative codebook search as follows:

$$r_{updt}(n) = r(n) - g_q \cdot q(n) - g_{p,updt} \cdot v(n). \quad (17)$$

The innovative codebook search is then applied as in the ACELP model.

Transform-Domain Codebook in the Decoder

Referring back to FIG. 4, at the decoder, the excitation contribution **409** from the transform-domain codebook stage **420** is obtained from the received transform-domain codebook parameters including the quantized transform-domain DCT coefficients $Q_d(k)$ and the transform-domain codebook gain g_q .

The transform-domain codebook first de-quantizes the received, decoded (quantized) quantized transform-domain DCT coefficients $Q_d(k)$ using, for example, an AVQ decoder **404** to produce de-quantized transform-domain DCT coefficients. An inverse transform, for example inverse DCT (iDCT), is applied to these de-quantized transform-domain DCT coefficients through an inverse transform calculator **405**. At the decoder, the transform-domain codebook applies a de-emphasis filter $1/F(z)$ **406** after the inverse DCT transform to form the time-domain excitation signal $q(n)$ **407**. The transform-domain codebook stage **420** then scales, by means of an amplifier **407** using the transform-domain codebook gain g_q , the time-domain excitation signal $q(n)$ **407** to form the transform-domain codebook excitation contribution **409**.

The total excitation **408** is then formed through summation in an adder **410** of the adaptive codebook excitation contribution **203**, the transform-domain codebook excitation contribution **409**, and the innovative codebook excitation contribution **206**. The total excitation **408** is then processed through the LP synthesis filter $1/A(z)$ **208** to produce a synthesis $s'(n)$ of the original sound signal, for example speech.

Transform-Domain Codebook Bit-Budget

Usually the higher the bit-rate, the more bits are used by the transform-domain codebook leaving the size of the innovative codebook the same across the different bit-rates. The above disclosed first structure of modified CELP model can be used at high bit rates (around 48 kbit/s and higher) to encode speech signals practically transparently and to efficiently encode generic audio signals as well.

At such high bit rates the vector quantizer of the adaptive and innovative codebook gains may be replaced by two scalar quantizers. More specifically, a linear scalar quantizer is used to quantize the adaptive codebook gain g_p and a logarithmic scalar quantizer is used to quantize the innovative codebook gain g_c .

Second Structure of Modified CELP Model

The above described first structure of modified CELP model using a transform-domain codebook stage followed by an innovative codebook stage (FIG. 3) can be further adaptively changed depending on the characteristics of the input sound signal. For example, in coding of inactive speech segments, it may be advantageous to change the order of the transform-domain codebook stage and the ACELP innovative codebook stage. Therefore, the second structure of modified CELP model uses a second codebook arrangement combining the time-domain adaptive codebook in a first codebook stage followed by a time-domain ACELP innovative codebook in a second codebook stage followed by a transform-domain codebook in a third codebook stage. The ACELP innovative codebook of the second stage usually may comprise very small codebooks and may even be avoided.

Contrary to the first structure of modified CELP model where the transform-domain codebook stage can be seen as a pre-quantizer for the innovative codebook stage, the transform-domain codebook stage in the second codebook arrangement of the second structure of modified CELP model is used as a stand-alone third-stage quantizer (or a second-stage quantizer if the innovative codebook stage is not used). Although the transform-domain codebook stage puts usually more weights in coding the perceptually more important lower frequencies, contrary to the transform-domain codebook stage in the first codebook arrangement to whiten the excitation residual after subtraction of the adaptive and innovative codebook excitation contributions in all the frequency range. This can be desirable in coding the noise-like (inactive) segments of the input sound signal.

Computation of the Target Signal for the Transform-Domain Codebook

Referring to FIG. 5, which is a block diagram of the second structure of modified CELP model, the transform-domain codebook stage **520** operates as follows. In a given sub-frame, the target signal for the transform-domain codebook search $x_3(n)$ **518** is computed by a calculator using the subtractor **104** subtracting from the adaptive codebook search target signal $x_1(n)$ the filtered adaptive codebook excitation signal $y_1(n)$ scaled by the amplifier **106** using adaptive codebook gain g_p to form the innovative codebook search target signal $x_2(n)$, and a subtractor **525** subtracting from the innovative codebook search target signal $x_2(n)$ the filtered innovative codebook excitation signal $y_2(n)$ scaled by the amplifier **109** using innovative codebook gain g_c (if the innovative codebook is used), as follows:

$$x_3(n) = x_1(n) - g_p \cdot y_1(n) - g_c \cdot y_2(n) \quad n=0, \dots, N-1. \quad (18)$$

The calculator also filters the target signal for the transform-domain codebook search $x_3(n)$ **518** through the inverse of the weighted synthesis filter $H(z)$ with zero states resulting in the residual domain target signal for the transform-domain codebook search $u_m(n)$ **500**.

Pre-Emphasis Filtering

The signal $u_m(n)$ **500** is used as the input signal to the transform-domain codebook search. In this non-limitative example, in the transform-domain codebook, the signal $u_m(n)$ **500** is first pre-emphasized with filter $F(z)$ **301** to produce pre-emphasized signal $u_{m,d}(n)$ **502**. An example of such a pre-emphasis filter is given by Equation (9). The filter of Equation (9) applies a spectral tilt to the signal $u_m(n)$ **500** to enhance the lower frequencies.

Transform Calculation

The transform-domain codebook also comprises, for example, a DCT applied by the transform calculator **303** to the pre-emphasized signal $u_{m,d}(n)$ **502** using, for example, a rectangular non-overlapping window to produce blocks of transform-domain DCT coefficients $U_{m,d}(k)$ **504**. An example of the DCT is given in Equation (10).

Quantization

Usually all blocks of transform-domain DCT coefficients $U_{m,d}(k)$ **504** are quantized using, for example, the AVQ encoder **305** to produce quantized transform-domain DCT coefficients $U_d(k)$ **506**. The quantized transform-domain DCT coefficients $U_d(k)$ **506** can be however set to zero at low bit rates as explained in the foregoing description. Contrary to the transform-domain codebook of the first codebook arrangement, the AVQ encoder **305** may be used to encode blocks with the highest energy across all the bandwidth instead of forcing the AVQ to encode the blocks corresponding to lower frequencies.

Similarly to the first codebook arrangement, a bit-budget allocated to the AVQ in every sub-frame is composed as a sum of a fixed bit-budget and a floating number of bits. The indices of the coded, quantized transform-domain DCT coefficients $U_d(k)$ **506** from the AVQ encoder **305** are transmitted as transform-domain codebook parameters to the decoder.

In another non-limitative example, the quantization can be performed by minimizing the mean square error in a perceptually weighted domain as in the CELP codebook search. The pre-emphasis filter $F(z)$ **301** described above can be seen as a simple form of perceptual weighting. More elaborate perceptual weighting can be performed by filtering the signal $u_m(n)$ **500** prior to transform and quantization. For example, replacing the pre-emphasis filter $F(z)$ **301** by the weighted synthesis filter $W(z)/A(z)$ is equivalent to transforming and quantizing the target signal $x_3(n)$. The perceptual weighting can be also applied in the transform domain, e.g. by multiplying the transform-domain DCT coefficients $U_{m,d}(k)$ **504** by a frequency mask prior to quantization. This will eliminate the need of pre-emphasis and de-emphasis filtering. The frequency mask could be derived from the weighted synthesis filter $W(z)/A(z)$.

Inverse Transform Calculation

The quantized transform-domain DCT coefficients $U_d(k)$ **506** are inverse transformed in inverse transform calculator **307** using, for example, an inverse DCT (iDCT) to produce an inverse transformed, emphasized quantized excitation $u_d(n)$ **508**. An example of the inverse transform is given in Equation (11).

De-Emphasis Filtering

The inverse transformed, emphasized quantized excitation $u_d(n)$ **508** is processed through the de-emphasis filter $1/F(z)$ **309** to obtain a time-domain excitation signal from the transform-domain codebook stage $u(n)$ **510**. The de-emphasis filter **309** has the inverse transfer function of the pre-emphasis filter $F(z)$ **301**; in the non-limitative example for pre-emphasis filter $F(z)$ described above, the transfer function of the de-emphasis filter **309** is given by Equation (12).

The signal $y_3(n)$ **516** is the transform-domain codebook excitation signal obtained by filtering the time-domain excitation signal $u(n)$ **510** through the weighted synthesis filter $H(z)$ **311** (i.e. the zero-state response of the weighted synthesis filter $H(z)$ **311** to the time-domain excitation signal $u(n)$ **510**).

Finally, the transform-domain codebook excitation signal $y_3(n)$ **516** is scaled by the amplifier **312** using transform-domain codebook gain g_q .

Transform-Domain Codebook Gain Calculation and Quantization

Once the transform-domain codebook excitation contribution $u(n)$ **510** is computed, the transform-domain codebook gain g_q is obtained using the following relation:

$$g_q = \frac{\sum_{k=0}^{N-1} U_{m,d}(k)U_d(k)}{\sum_{k=0}^{N-1} U_d(k)U_d(k)}, \quad (19)$$

where $U_{m,d}(k)$ **504** the AVQ input transform-domain DCT coefficients and $U_d(k)$ **506** are the AVQ output quantized transform-domain DCT coefficients.

The transform-domain codebook gain g_q is quantized using the normalization by the innovative codebook gain g_c . In one example, a 6-bit scalar quantizer is used whereby the quantization levels are uniformly distributed in the linear domain. The index of the quantized transform-domain codebook gain g_q is transmitted as transform-domain codebook parameter to the decoder.

Limitation of the Adaptive Codebook Contribution

When coding the inactive sound signal segments, for example inactive speech segments, the adaptive codebook excitation contribution is limited to avoid a strong periodicity in the synthesis. In practice, the adaptive codebook gain g_p is usually constrained by $0 \leq g_p \leq 1.2$. When coding an inactive sound signal segment, a limiter is provided in the adaptive codebook search to constrain the adaptive codebook gain g_p by $0 \leq g_p \leq 0.65$.

Transform-Domain Codebook in the Decoder

At the decoder, the excitation contribution from the transform-domain codebook is obtained by first de-quantizing the decoded (quantized) transform-domain (DCT) coefficients (using, for example, an AVQ decoder (not shown)) and applying the inverse transform (for example inverse DCT (iDCT)) to these de-quantized transform-domain (DCT) coefficients. Finally, the de-emphasis filter $1/F(z)$ is applied after the inverse DCT transform to form the time-domain excitation signal $u(n)$ scaled by the transform-domain codebook gain g_q (see transform-domain codebook **402** of FIG. 4).

At the decoder, the order of codebooks and corresponding codebook stages during the decoding process is not important as a particular codebook contribution does not depend on or affect other codebook contributions. Thus the second codebook arrangement in the second structure of modified CELP model can be identical to the first codebook arrangement of the first structure of modified CELP model of FIG. 4 with $q(n)=u(n)$ and the total excitation is given by Equation (7).

Finally, the transform-domain codebook is searched by subtracting through a subtractor **530** (a) the time-domain excitation signal from the transform-domain codebook stage $u(n)$ processed through the weighted synthesis filter $H(z)$ **311** and scaled by transform-domain codebook gain g_q from (b) the transform-domain codebook search target signal $x_3(n)$

518, and minimizing error criterion $\min \{|\text{error}(n)|^2\}$ in calculator 511, as illustrated in FIG. 5.

General Modified CELP Model

A general modified CELP coder with a plurality of possible structures is shown in FIG. 6.

The CELP coder of FIG. 6 comprises a selector of an order of the time-domain CELP codebook and the transform-domain codebook in the second and third codebook stages, respectively, as a function of characteristics of the input sound signal. The selector may also be responsive to the bit rate of the codec using the modified CELP model to select no codebook in the third stage, more specifically to bypass the third stage. In the latter case, no third codebook stage follows the second one.

As illustrated in FIG. 6, the selector may comprise a classifier 601 responsive to the input sound signal such as speech to classify each of the successive frames for example as active speech frame (or segment) or inactive speech frame (or segment). The output of the classifier 601 is used to drive a first switch 602 which determines if the second codebook stage after the adaptive codebook stage is ACELP coding 604 or transform-domain (TD) coding 605. Further, a second switch 603 also driven by the output of the classifier 601 determines if the second ACELP stage 604 is followed by a TD stage or if the second TD stage 605 is followed by an ACELP stage 607. Moreover, the classifier 601 may operate the second switch 603 in relation to an active or inactive speech frame and a bit rate of the codec using the modified CELP model, so that no further stage follows the second ACELP stage 604 or second TD stage 605.

In an illustrative example, the number of codebooks (stages) and their order in a modified CELP model are shown in Table I. As can be seen in Table I, the decision by the classifier 601 depends on the signal type (active or inactive speech frames) and on the codec bit-rate.

TABLE I

Codebooks in an example of modified CELP model (ACB stands for adaptive codebook and TDCB for transform-domain codebook)		
Codec Bit Rate	Active Speech Frames	Inactive Speech Frames
16 kbit/s	ACB→ACELP	ACB→ACELP
24 kbit/s	ACB→ACELP	ACB→ACELP
32 kbit/s	ACB→TDCB→ACELP	ACB→ACELP→TDCB
48 kbit/s	ACB→TDCB→ACELP	ACB→ACELP→TDCB

Although examples of implementation are given herein above with reference to an ACELP model, it should be kept in mind that a CELP model other than ACELP could be used. It should also be noted that the use of DCT and AVQ are examples only; other transforms can be implemented and other methods to quantize the transform-domain coefficients can also be used.

What is claimed is:

1. A Code-Excited Linear Prediction (CELP) codebook coding device for encoding sound into first, second, and third sets of encoding parameters, comprising:

- a first calculator of a first target signal for an adaptive codebook search in response to an input sound signal;
- a CELP adaptive codebook stage structured to search, in response to the first target signal, an adaptive codebook to find an adaptive codebook index and an adaptive codebook gain, the adaptive codebook index and gain forming the first set of encoding parameters;
- a CELP innovative codebook stage structured to search, in response to a second target signal, a CELP innovative

codebook to find an innovative codebook index and an innovative codebook gain, the innovative codebook index and gain forming the second set of encoding parameters;

- 5 a transform-domain codebook stage structured to calculate, in response to a third target signal, transform-domain coefficients and a transform-domain codebook gain, the transform-domain coefficients and the transform-domain codebook gain forming the third set of encoding parameters;

a second calculator of the second target signal and a third calculator of the third target signal;

a selector of an order of the CELP innovative codebook stage and the transform-domain codebook stage as a function of at least one of (a) characteristics of the input sound signal and (b) a bit rate of a codec using the CELP codebook coding device, wherein the selector comprises switches having a first position where the CELP innovative codebook stage is first and followed by the transform-domain codebook stage and a second position where the transform-domain codebook stage is first and followed by the CELP innovative codebook stage, and wherein:

in the first position of the switches, the second calculator determines the second target signal using the first target signal and information from the CELP adaptive codebook stage and the third calculator determines the third target signal using the second target signal and information from the CELP innovative codebook stage; and

in the second position of the switches, the third calculator determines the third target signal using the first target signal and information from the CELP adaptive codebook stage and the second calculator determines the second target signal using the first target signal and information from the CELP adaptive codebook stage and the transform-domain codebook stage,

wherein each of the first calculator, the CELP adaptive codebook stage, the CELP innovative codebook stage, the transform-domain codebook stage, the second calculator, the third calculator, and the selector is configured to be processed by one or more processors, wherein the one or more processors is coupled to a memory.

2. A CELP codebook coding device as defined in claim 1, wherein the selector is responsive to both the characteristics of the input sound signal and a bit rate of the codec using the CELP codebook coding device to bypass a last codebook stage amongst the CELP adaptive codebook stage and the transform-domain codebook stage.

3. A CELP codebook coding device as defined in claim 1, wherein the selector comprises a classifier of the input sound signal, and the switches are controlled by the classifier to change the order of the CELP innovative codebook stage and the transform-domain codebook stage.

4. A CELP codebook coding device as defined in claim 3, wherein the classifier classifies each of successive segments of the input sound signal as active speech segment or inactive speech segment.

5. A CELP codebook coding device as defined in claim 1, wherein the transform-domain codebook stage comprises a calculator of a transform of the third target signal and a quantizer of the transform-domain coefficients from the transform calculator.

6. A CELP codebook coding device as defined in claim 5, wherein the transform is a discrete cosine transform and the quantizer is an algebraic vector quantizer.

7. A CELP codebook coding device as defined in claim 5, wherein the transform-domain codebook stage comprises a

15

pre-emphasis filter processing the third target signal before supplying said third target signal to the transform calculator.

8. A CELP codebook coding device as defined in claim 5, wherein the transform-domain codebook stage further comprises a calculator of an inverse transform of the quantized transform-domain coefficients from the quantizer, a de-emphasis filter for processing the inverse transformed, quantized transform-domain coefficients to produce a time-domain excitation signal, a weighted synthesis filter for processing the time-domain excitation signal to produce a filtered transform-domain codebook excitation signal, and an amplifier using the transform-domain codebook gain for scaling the filtered transform-domain codebook excitation signal to produce a transform-domain codebook excitation contribution.

9. A CELP codebook coding device as defined in claim 5, wherein the adaptive codebook of the CELP adaptive codebook stage is supplied with an adaptive codebook index to produce an adaptive codebook vector, and wherein the calculator of the third target signal use the adaptive codebook vector when the transform-domain codebook follows the CELP adaptive codebook stage and the switches are in the second position.

10. A CELP codebook coding device as defined in claim 5, wherein:

the CELP adaptive codebook stage computes an adaptive codebook excitation contribution by supplying an adaptive codebook index to the adaptive codebook to produce an adaptive codebook vector, processing the adaptive codebook vector through a weighted synthesis filter to produce a filtered adaptive codebook excitation signal, and amplifying the filtered adaptive codebook excitation signal with an amplifier using an adaptive codebook gain to produce the adaptive codebook excitation contribution; and

the CELP innovative codebook stage computes an innovative codebook excitation contribution by applying an innovative codebook index to the CELP innovative codebook to produce an innovative codebook vector, processing the innovative codebook vector through a weighted synthesis filter to produce a filtered innovative codebook excitation signal, and amplifying the filtered innovative codebook excitation signal with an amplifier using an innovative codebook gain to produce the innovative codebook excitation contribution.

11. A CELP codebook coding device as defined in claim 10, wherein the third calculator uses the adaptive codebook excitation contribution and the innovative codebook excitation contribution when the transform-domain codebook stage is the last codebook stage and the switches are in the first position.

12. A CELP codebook coding device as defined in claim 5, wherein the transform-domain codebook stage comprises a bit budget allocated to the quantization by the quantizer that is a sum of a fixed bit budget and a floating number of bits.

13. A CELP codebook coding device as defined in claim 12, wherein the floating number of bits in a current sub-frame comprises bits unused for the quantization in a previous sub-frame.

14. A CELP codebook coding device as defined in claim 5, wherein the transform-domain codebook stage comprises a calculator of the transform-domain codebook gain using transform-domain coefficients from the transform calculator and quantized transform-domain coefficients from the quantizer.

15. A CELP codebook coding device as defined in claim 1, wherein the transform-domain codebook stage produces a transform-domain codebook excitation contribution, and

16

wherein the CELP innovative codebook stage uses the transform-domain codebook excitation contribution to refine the adaptive codebook gain.

16. A CELP codebook coding device as defined in claim 1, comprising a limiter of the adaptive codebook gain in the presence of inactive sound signal segments.

17. A Code-Excited Linear Prediction (CELP) codebook coding method for encoding sound into first, second and third sets of encoding parameters, comprising:

receiving a sound signal on an input from a microphone or a storage device;

calculating a first target signal for an adaptive codebook search in response to the input sound signal;

in a CELP adaptive codebook stage, searching in response to the first target signal an adaptive codebook to find an adaptive codebook index and an adaptive codebook gain, the adaptive codebook index and gain forming the first set of encoding parameters;

in a CELP innovative codebook stage, searching in response to a second target signal a CELP innovative codebook to find an innovative codebook index and an innovative codebook gain, the innovative codebook index and gain forming the second set of encoding parameters;

in a transform-domain codebook stage, calculating in response to a third target signal transform-domain coefficients and a transform-domain codebook gain, the transform-domain coefficients and the transform-domain codebook gain forming the third set of encoding parameters;

calculating the second target signal and the third target signal;

selecting an order of the CELP innovative codebook stage and the transform-domain codebook stage as a function of at least one of (a) characteristics of the input sound signal and (b) a bit rate of a codec using the CELP codebook coding method, wherein:

in a selected order where the CELP innovative codebook stage is first and followed by the transform-domain codebook stage, the second target signal is determined using the first target signal and information from the CELP adaptive codebook stage and the third target signal is determined using the second target signal and information from the CELP innovative codebook stage; and

in a selected order where the transform-domain codebook stage is first and followed by the CELP innovative codebook stage, the third target signal is determined using the first target signal and information from the CELP adaptive codebook stage and the second target signal is determined using the first target signal and information from the CELP adaptive codebook stage wherein each of the receiving, calculating, searching and selecting operation is configured to be processed by one or more processors, wherein the one or more processors is coupled to a memory.

18. A CELP codebook coding method as defined in claim 17, comprising bypassing, in response to both the characteristics of the input sound signal and the bit rate of the codec using the CELP codebook coding method, a last codebook stage amongst the CELP innovative codebook stage and the transform-domain codebook stage.

19. A CELP codebook coding method as defined in claim 17, wherein the selection of the order of the CELP innovative codebook stage and the transform-domain codebook stage comprises classifying the input sound signal and changing the

17

order of the CELP innovative codebook stage and the transform-domain codebook stage in response to said classification.

20. A CELP codebook coding method as defined in claim 19, wherein each of successive segments of the input sound signal is classified as active speech segment or inactive speech segment.

21. A CELP codebook coding method as defined in claim 17, wherein, in the transform-domain codebook stage, calculating transform-domain coefficients comprises calculating a transform of the third target signal and quantizing the transform-domain coefficients from the transform calculation.

22. A CELP codebook coding method as defined in claim 21, wherein the transform is a discrete cosine transform and the quantization of the transform-domain coefficients is an algebraic vector quantization.

23. A CELP codebook coding method as defined in claim 21, comprising processing, in the transform-domain codebook stage, the third target signal through a pre-emphasis filter before calculating the transform of said third target signal.

24. A CELP codebook coding method as defined in claim 21, comprising, in the transform-domain codebook stage, calculating an inverse transform of the quantized transform-domain coefficients, processing the inverse transformed, quantized transform-domain coefficients through a de-emphasis filter to produce a time-domain excitation signal, processing the time-domain excitation signal through a weighted synthesis filter to produce a filtered transform-domain codebook excitation signal, and amplifying the filtered transform-domain codebook excitation signal using the transform-domain codebook gain to scale the filtered transform-domain codebook excitation signal to produce a transform-domain codebook excitation contribution.

25. A CELP codebook coding method as defined in claim 21, comprising supplying the adaptive codebook of the CELP adaptive codebook stage with an adaptive codebook index to produce an adaptive codebook vector, and calculating the third target signal using the adaptive codebook vector when the transform-domain codebook stage follows the CELP adaptive codebook stage.

26. A CELP codebook coding method as defined in claim 21, comprising:

computing, in the CELP adaptive codebook stage, an adaptive codebook excitation contribution by supplying an adaptive codebook index to the adaptive codebook to

18

produce an adaptive codebook vector, processing the adaptive codebook vector through a weighted synthesis filter to produce a filtered adaptive codebook excitation signal, and amplifying the filtered adaptive codebook excitation signal with an amplifier using an adaptive codebook gain to produce the adaptive codebook excitation contribution; and

computing, in the CELP innovative codebook stage, an innovative codebook excitation contribution by applying an innovative codebook index to the CELP innovative codebook to produce an innovative codebook vector, processing the innovative codebook vector through a weighted synthesis filter to produce a filtered innovative codebook excitation signal, and amplifying the filtered innovative codebook excitation signal with an amplifier using an innovative codebook gain to produce the innovative codebook excitation contribution.

27. A CELP codebook coding method as defined in claim 26, wherein the third target signal is calculated using the adaptive codebook excitation contribution and the innovative codebook excitation contribution when the transform-domain codebook stage is the last codebook stage.

28. A CELP codebook coding method as defined in claim 21, comprising allocating, in the transform-domain codebook stage, a bit budget to the quantization of the transform-domain coefficients that is a sum of a fixed bit budget and a floating number of bits.

29. A CELP codebook coding method as defined in claim 28, wherein the floating number of bits in a current sub-frame comprises bits unused for the quantization in a previous sub-frame.

30. A CELP codebook coding method as defined in claim 21, comprising, in the transform-domain codebook stage, calculating the transform-domain codebook gain using the transform-domain coefficients and the quantized transform-domain coefficients.

31. A CELP codebook coding method as defined in claim 17, comprising producing, in the transform-domain codebook stage, a transform-domain codebook excitation contribution, and using, in the CELP innovative codebook stage, the transform-domain codebook excitation contribution to refine the adaptive codebook gain.

32. A CELP codebook coding method as defined in claim 17, comprising limiting the adaptive codebook gain in the presence of inactive sound signal segments.

* * * * *